



# MRS-600HE-II High Efficiency Reverse Osmosis System

High output/high efficiency configurable system that delivers reverse osmosis or blended filtered water for multiple foodservice applications.



**MRS-600HE-II System:**  
 EV9970-54 (USA - 110-120VAC/50-60Hz)  
 EV9970-70 (Europe - 220-240VAC/50-60Hz)  
 EV9970-71 (China - 220-240VAC/50-60Hz)  
 EV9970-72 (Australia - 220-240VAC/50-60Hz)

**MR-600 Cartridge:** EV9627-13  
**7FS-BW Cartridge:** EV9627-16  
**MC<sup>2</sup> Cartridge:** EV9612-56

## BENEFITS

The tailored blending process removes just the right amount of dissolved solids from the incoming tap water to achieve the desired final water quality

High recovery reverse osmosis technology yields significant savings in water and sewer charges with a minimal environmental footprint

With the average recovery of 78%, the MRS-600HE-II system only disposes approximately 1/4 cup of water for each cup of water dispensed

Requires less than 50% of the electrical energy typically consumed by conventional reverse osmosis systems

System operation is tailored to the water quality at each location to maximize recovery

Reduces limescale build-up that can cause excessive machine downtime and increased maintenance costs

Reduces chlorine taste and odor and other contaminants that can adversely affect the taste of water and beverages

## INSTALLATION TIPS

Choose a mounting location capable of safely supporting the full weight of the system when in operation

Delimiting of existing water using equipment is recommended

Never use saddle valve for connection

Use 3/8" (9.5 mm) minimum water line

Water inlet must supply a minimum of 1.5 gpm (5.7 lpm)

Install vertically with cartridges hanging down and allow 3" (76 mm) on all four sides of unit for cover removal and service access

The product water tubing/piping and associated fittings connecting the RO product outlet to the equipment being serviced should be suitable for use with high purity water

Refer to Installation, Operation & Maintenance Manual for cartridge flushing and RO start-up

## OPERATION TIPS

Change filter cartridges on a regular 1 year preventative maintenance program

Change RO cartridges on a regular 1 year preventative maintenance program

Change cartridges when capacity is reached

Always flush the filter cartridge at time of installation and cartridge change

## APPLICATION / SIZING

Mineral Reduction System for foodservice applications including coffee brewers, espresso machines, steamers, combi ovens, and ice – ideal for specialty coffee

### Daily Production Rate

#### RO Processor Only:

600 gpd (2,271 lpd) nominal  
 0.417 gpm (1.58 lpm) nominal

#### RO Processor with Blend:

Capacity will vary based on tap water TDS, RO percent rejection and desired blend water TDS – An example of the adjusted capacity is shown below.

**Example:** 500 ppm tap water, 90% rejection, 100 ppm blend setting

**Result:** 600 GPD RO Processor Only + 75 GPD filtered tap water =  
 675 gpd (2,555 lpd) nominal  
 0.469 gpm (1.77 lpm) nominal

## SPECIFICATIONS

### Overall Dimensions:

33" H x 23" W x 13" D  
 838 mm H x 584 mm W x 330 mm D  
 [Add 3" (76 mm) on all 4 sides for cover removal and service access]

### Inlet and outlet connection:

3/8" (9.5 mm) OD tube connection

### Wastewater line connection:

3/8" (9.5 mm) OD tube connection

### Daily Production Rate:

Processor Only (no blend):

600 gpd (2,271 lpd) nominal  
 0.417 gpm (1.58 lpm) nominal

Processor with Blend:

600 gpd (2,271 lpd) nominal  
 plus tap water addition

- Total daily production rate will vary based on tap water TDS, RO percent rejection and desired blend water TDS - Contact Everpure for assistance estimating this total

### Service Flow Rate:

Dependant on water pressure in storage tank and line size(s) to equipment

### Pressure Requirements:

Operating:

25 - 80 psi (1.72-5.52 bar), non-shock  
 [Pressure below 50 psi (3.45 bar) may affect blend system performance]

Maximum Static:

100 psi (6.89 bar), non-shock

### Available Voltages and Power Cord Plug Types:

EV9970-54: USA - 110-120VAC/50-60Hz - NEMA 5-15P  
 EV9970-70: Europe - 220-240VAC/50-60Hz - CEE 7/7 C  
 EV9970-71: China - 220-240VAC/50-60Hz - GB 2099  
 EV9970-72: Australia - 220-240VAC/50-60Hz - AS 3112

Minimum Water Supply: 1.5 gpm (5.7 lpm)

Inlet Temperature: 40-100°F (4-38°C)

Inlet TDS: 1000 ppm max. recommended

Shipping Weight: 100 lbs. (45.4 Kg)

Operating Weight: 110 lbs. (49.9 Kg)  
 (not including external storage tanks)

The contaminants or other substances removed or reduced by this system are not necessarily in your water. Do not use with water that is microbiologically unsafe or of unknown quality without adequate disinfection before or after the system.

# MRS-600HE-II High Efficiency Reverse Osmosis System

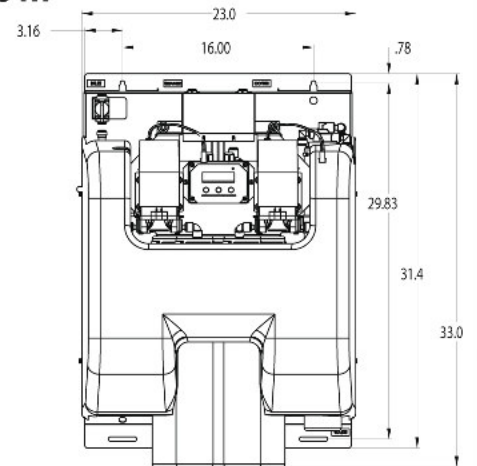
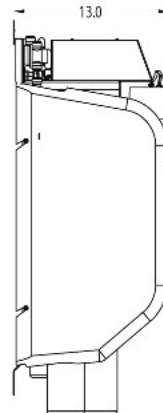
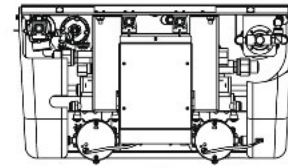

### Power Cord Plug Types



NEMA 5-15P

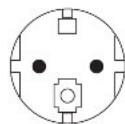

CEE 7/7 "Schuko"



GB 2009  
 AS 3112

## WARRANTY

MRS-600HE-II system (excluding replaceable elements) is covered by a limited warranty against defects in material and workmanship for a period of one year after the date of purchase.

Everpure replaceable elements (filter cartridges and water treatment cartridges) are covered by a limited warranty against defects in material and workmanship for a period of one year after date of purchase.

See printed warranty for details. Everpure will provide a copy of the warranty upon request.



Everpure offers a full line of water storage tanks. See "ROmate Storage Tanks" specification sheet or contact your Everpure sales representative for more information.



# Liberty

Ersatzteile & Zubehör

Liberty Vertriebs GmbH  
 Bonner Straße 103  
 40589 Düsseldorf

Tel.: 0211-753520  
 Fax.: 0211-753575

Internet: [www.libertyshop.de](http://www.libertyshop.de)  
 Email: [verkauf@libertyshop.de](mailto:verkauf@libertyshop.de)