



EV9612-61

2K-Plus Filter Cartridge

Delivers premium quality water for foodservice, vending and OCS applications



2K-Plus Replacement Cartridge:
EV9612-61

BENEFITS

Provides sparkling clear, fresh, premium quality ingredient water for great tasting beverages

Everpure's unique filter blend using activated carbon reduces chlorine taste and odor and other offensive contaminants

KDF[®] Media inhibits microbial growth and provides bacteriostatic control plus scale inhibition

Precoat submicron technology reduces dirt and particles as small as 1/2 micron in size

Reduces possible health contaminants such as asbestos fibers and Cryptosporidium and Giardia cysts

Sanitary cartridge replacement is simple, quick, and clean. Internal filter parts are never exposed to handling or contamination

NSF Certified under NSF/ANSI Standards 42 and 53

INSTALLATION TIPS

Never use saddle valve for connection

Use 3/8" water line

Install vertically with cartridge hanging down

Allow 2-1/2" clearance below the cartridge for easy cartridge replacement

Flush 2K Plus cartridge by running water through filter for three minutes at full flow

OPERATION TIPS

Change cartridges on a regular 6 month preventative maintenance program

Change cartridges when capacity is reached or when pressure falls below 10 psi

Service flow rate must not exceed 0,5 gpm

Always flush the filter cartridge at time of installation and cartridge change

APPLICATION/SIZING

For foodservice, vending machine and office coffee service applications

Rated Capacity: 1,500 gallons (5,678L)

2K-Plus Filter Cartridge

SPECIFICATIONS

Overall Dimensions:
10.25"H x 3.25"Diameter

Service Flow Rate:
Maximum 0.5 gpm (1.9 Lpm)

Rated Capacity: 1,500 gallons

Pressure Requirements:
10 - 125 psi (0.7 – 8.6 bar), non-shock

Maximum Temperature: 35 - 100°F (2 - 38°C)

No electrical connection required

KDF® is the registered trademark of KDF
Fluid Treatment, Inc.

The contaminants or other substances removed or reduced by this drinking water system are not necessarily in your water. Do not use with water that is microbiologically unsafe or of unknown quality without adequate disinfection before or after the system. Systems certified for cyst reduction may be used with disinfected water that may contain filterable cysts.

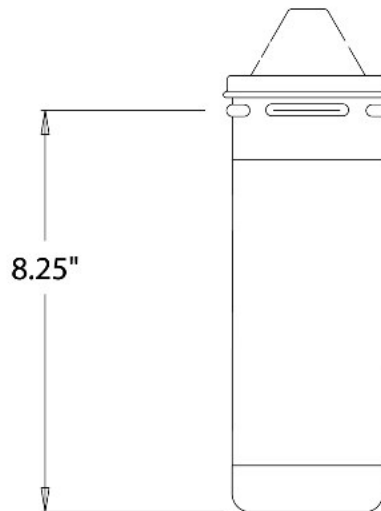

WARRANTY

Everpure water treatment systems (excluding replaceable elements) are covered by a limited warranty against defects in material and workmanship for a period of five years after date of purchase. Everpure replaceable elements (filter cartridges and water treatment cartridges) are covered by a limited warranty against defects in material and workmanship for a period of one year after date of purchase. See printed warranty for details. Everpure will provide a copy of the warranty upon request.



System Tested and Certified by NSF International against NSF/ANSI Standard 42 and 53 for the reduction of:

Standard No. 42: Aesthetic Effects
Chemical Unit
Taste and Odor Reduction
Chlorine Reduction
Mechanical Filtration Unit
Particulate Reduction, Class I:
99.9+% reduction of particles
one-half micron and larger in size
Standard No. 53: Health Effects
Mechanical Filtration Unit
Turbidity Reduction
Cyst Reduction
Asbestos Reduction



Liberty
Ersatzteile & Zubehör

Liberty Vertriebs GmbH
Bonner Straße 103
40589 Düsseldorf

Tel.: 0211-753520
Fax.: 0211-753575

Internet: www.libertyshop.de
Email: verkauf@libertyshop.de