



EV9617-05

# 2CB5 Replacement Cartridge

Delivers quality water for foodservice, vending and OCS applications



2CB5 Replacement Cartridge:  
EV9617-05

## BENEFITS

Carbon block filter finely polishes water for high quality beverage and food applications

Reduces chlorine taste and odor and other offensive contaminants that can adversely affect the taste of water and beverages

Reduces extra fine dirt and particles as small as 5 micron in size

Does not remove fluoride

Sanitary cartridge replacement is simple, quick and clean. Internal filter parts are never exposed to handling or contamination

NSF Certified under NSF/ANSI Standard 42

## INSTALLATION TIPS

Never use saddle valve for connection

Use 3/8" water line

Install vertically with cartridge hanging down

Allow 2-1/2" clearance below the cartridge for easy cartridge replacement

Flush 2CB5 cartridge by running water through filter for 5 minutes at full flow

## OPERATION TIPS

Change cartridges on a regular 6 month preventative maintenance program

Change cartridges when capacity is reached or when pressure falls below 10 psi

Service flow rate must not exceed 1.0 gpm

Always flush the filter cartridge at time of installation and cartridge change

## APPLICATION/SIZING

Ideal for problem water areas

For foodservice, vending machine and office coffee service applications

Rated Capacity: 3,000 gallons (11,355 L)

# 2CB5 Replacement Cartridge

## SPECIFICATIONS

**Overall Dimensions:**

10.25"H x 3.25"Diameter

**Service Flow Rate:**

Maximum 1 gpm (3.8 Lpm)

**Rated Capacity:** 3,000 gallons

**Pressure Requirements:**

10 - 125 psi (0.7 – 8.6 bar), non-shock

**Maximum Temperature:** 35 - 100°F (2 - 38°C)

No electrical connection required

The contaminants or other substances removed or reduced by this drinking water system are not necessarily in your water. Do not use with water that is microbiologically unsafe or of unknown quality without adequate disinfection before or after the system. Systems certified for cyst reduction may be used with disinfected water that may contain filterable cysts.

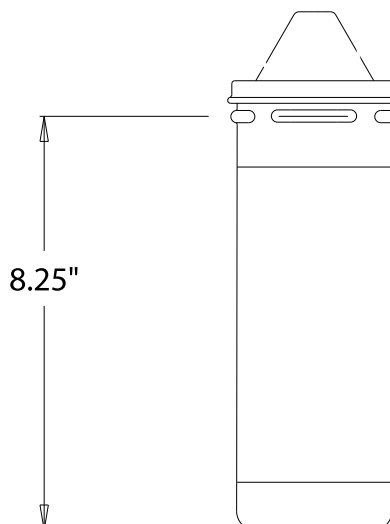

## WARRANTY

Everpure water treatment systems (excluding replaceable elements) are covered by a limited warranty against defects in material and workmanship for a period of five years after date of purchase. Everpure replaceable elements (filter cartridges and water treatment cartridges) are covered by a limited warranty against defects in material and workmanship for a period of one year after date of purchase. See printed warranty for details. Everpure will provide a copy of the warranty upon request.



System Tested and Certified by NSF International against NSF/ANSI Standard 42 for the reduction of:

Standard No. 42: Aesthetic Effects  
Chemical Unit  
Taste and Odor Reduction  
Chlorine Reduction



**Liberty**  
Ersatzteile & Zubehör

Liberty Vertriebs GmbH  
Bonner Straße 103  
40589 Düsseldorf

Tel.: 0211-753520  
Fax.: 0211-753575

Internet: [www.libertyshop.de](http://www.libertyshop.de)  
Email: [verkauf@libertyshop.de](mailto:verkauf@libertyshop.de)