

2K-Plus Filter Cartridge

Delivers premium quality water for foodservice, vending and OCS applications.

EVERPURE

APPLICATIONS

Foodservice
Vending Machine
Office Coffee Service

FEATURES AND BENEFITS

Provides sparkling clear, fresh, premium quality ingredient water for great tasting beverages.

Everpure's unique filter blend using activated carbon reduces chlorine taste and odor and other offensive contaminants.

KDF® Media inhibits microbial growth and provides bacteriostatic control plus scale inhibition.*

Precoat submicron technology reduces dirt and particles as small as 1/2 micron in size.

Reduces health contaminants such as asbestos fibers and Cryptosporidium and Giardia cysts.

Sanitary cartridge replacement is simple, quick and clean. Internal filter parts are never exposed to handling or contamination.

NSF Certified under NSF/ANSI Standards 42 and 53.

KDF® is the registered trademark of KDF Fluid Treatment, Inc.

*As tested by KDF.

OPERATIONAL TIPS

Change cartridges on a regular 6 month preventative maintenance program.

Change cartridges when capacity is reached or when pressure falls below 10 psi.

Service flow rate must not exceed 0.5 gpm.

Always flush the filter cartridge at time of installation and cartridge change.

Everpure water treatment systems (excluding replaceable elements) are covered by a limited warranty against defects in material and workmanship for a period of five years after date of purchase. Everpure replaceable elements (filter cartridges and water treatment cartridges) are covered by a limited warranty against defects in material and workmanship for a period of one year after date of purchase. See printed warranty for details. Everpure will provide a copy of the warranty upon request.



2K-Plus Replacement Cartridge: EV9612-61

SPECIFICATIONS

Overall Dimensions:	10.25" H x 3.25" D (26.0 x 8.3 cm)
Service Flow Rate:	Maximum 0.5 gpm (1.9 Lpm)
Rated Capacity:	1,500 gallons (5,678 L)
Pressure Requirements:	10 – 125 psi (0.7 – 8.6 bar), non-shock
Temperature:	35 – 100°F (2 – 38°C)
Electrical Connection:	None

2K-Plus Filter Cartridge

EV9612-61

INSTALLATION TIPS

Never use saddle valve for connection.

Use 3/8" water line.

Install vertically with cartridge hanging down.

Allow 2-1/2" clearance below the cartridge for easy cartridge replacement.

Flush 2K-Plus cartridge by running water through system for three minutes at full flow.

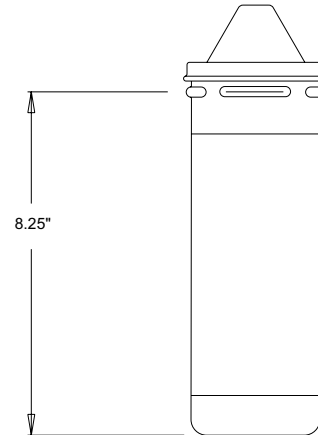

The contaminants or other substances removed or reduced by this drinking water system are not necessarily in your water. Do not use with water that is microbiologically unsafe or of unknown quality without adequate disinfection before or after the system. Systems certified for cyst reduction may be used with disinfected water that may contain filterable cysts.

EVERPURE reserves the right to update specifications, change prices, or make substitutions without notice.



System Tested and Certified by NSF International against NSF/ANSI Standard 42 and 53 for the reduction of:

Standard No. 42: Aesthetic Effects
Chemical Unit
Taste and Odor Reduction
Chlorine Reduction
Mechanical Filtration Unit
Particulate Reduction, Class I
Standard No. 53: Health Effects
Mechanical Filtration Unit
Turbidity Reduction
Cyst Reduction
Asbestos Reduction



Liberty

Ersatzteile & Zubehör

Liberty Vertriebs GmbH
Bonner Straße 103
40589 Düsseldorf

Tel.: 0211-753520
Fax.: 0211-753575

Internet: www.libertyshop.de
Email: verkauf@libertyshop.de